

*fanfare* FM<sup>TM</sup>

FT-1

Reference Quality

Digital / Analog

FM Tuner

Owner's Manual

# CONTENTS

Contents .....	1
Welcome to FANFARE FM™ .....	2
Features of the FT-1 .....	3
Design and Construction .....	3
Setting Up the FT-1 .....	4
Rear Panel Connections and Layout .....	5
Operating the FT-1 .....	6
Front Panel and Remote Controller Functions .....	7
The FT-1 'Under the Hood' .....	8
What is UNISET™ ? .....	9
Improving Your FM Reception .....	9
Typical FM Antennas .....	10
Choosing an FM Antenna .....	11
Gain and the FM Antenna .....	12
Antenna Download Cabling .....	12
Noise and Interference .....	12
Warranty Information .....	13
Specifications .....	13
In Case of Difficulty .....	14
Servicing the Remote Controller .....	14
APPENDICES .....	15

## Welcome to *fanfare*™ FM

While FANFARE FM™ is a relatively new name on the audio scene, the philosophy under which its management operates has been a personal code of ethics of mine for years. It is a philosophy that, in its simplest form, assures FANFARE dealers and their customers that we have but one objective . . . complete customer satisfaction.

We also realize you have put a lot of time into making the decision to purchase a FANFARE FT-1. After all, it has been only during the past few years that FM has been recognized as more than just a part of the background. Today, of the 5,000+ FM stations in the U.S. and Canada, more and more are being found to have remarkably pleasing fidelity. However, it took an FM tuner, like the FT-1, to realize the full potential from this exciting discovery.

For that reason, FANFARE has taken an active interest, not only in the quality of reproduction the FT-1 must provide, but in the quality of the signal that leaves the FM station. Therefore, in order to make FM stations more aware of the growing audience of discerning listeners with good quality, FM tuners, such as the FANFARE FT-1, we have begun asking them the following simple question.

*"How do you know how good you sound, if you can't tell how good you sound?"*

In order to help provide an accurate answer to that question, the FT-1 has been specially designed to allow immediate incorporation into any FM broadcast station's monitor rack. Specific features such as 'Composite Output' and balanced audio outputs from the FT-1 allow the radio station's Chief Engineer, and anyone else in the station for that matter, to accurately monitor the quality of the signal's full audio fidelity. Also, for stations that must employ 'repeaters' to distribute their signal into poor reception areas, the FT-1 is ready to serve as a broadcast demodulator. This provides the radio station with reliable, full fidelity reception of their main signal for 'original quality' re-transmission at the repeater site.

Soon you will discover that, unlike the atonal quality of many FM tuners on the market today, the FT-1 reproduces all the subtle differences in each and every selection being played. As a matter of fact, it does this so well that many times during our exhibits I have had visitors ask which CD we were playing. And, I was just delighted to say "That's not just a CD playing, that's a CD playing over our FM tuner."

Finally, when you think of it, with all the out-of-print selections and all the 'first air plays' that occur every day on FM, there's a wealth of music out there to be heard. What's more, it's all free!

Thank you for choosing the FANFARE FT-1 as your FM tuner. If you have any questions, comments or criticisms, I am but a phone or a FAX call away.

Enjoy!

**Fanfare Electronics, Ltd.**

M. C. (Marv) Southcott  
President

© 1993 -2004 Fanfare Electronics, Ltd. This manual may not be reprinted or copied in any way without the written permission of Fanfare Electronics, Ltd.

™ "Fanfare FM" and "UNISET" are trademarks of Fanfare Electronics, Ltd.

## FEATURES OF THE FT-1

Designed to meet exacting standards, the FANFARE FT-1 is a highly sensitive FM tuner augmented by excellent selectivity and offering a host of important features. Not the least of these features is clear, full-spectrum stereo reception with excellent sonic accuracy and sound stage reproduction

### FT-1 features include;

- : Infra red remote control of all front panel functions.
- : 8 presets with exclusive UNISSET™ programming control.
- : Wide/narrow IF band switching for best selectivity.
- : 2 position 'DX' switching for long distance or 'local only' reception
- : Fast UP/DOWN manual tuning in 50KHz steps.
- : Auto-seek mode to automatically find listenable stereo FM stations.
- : Easy to read, fluorescent function display. (green is standard, but display filter (color) may be changed to suit system)
- : Optional 19" EIA or 17" black faceplate (other configurations available.) (May be replaced on site)
- : Silent, push-button control at both the remote controller or at the front panel.
- : Audiophile grade, silver-plated, OFC (stranded) internal audio interconnects.
- : 3 year limited warranty with transferability option.

### Other FT-1 features include;

- : Noise reduction circuitry to maintain ambient noise levels below usual minimums.
- : Two sets, unbalanced audio outputs (HI and LO).
- : One set, balanced audio outputs.
- : Composite Output (for use in FM broadcast station).
- : Detachable ISE-type power cord.
- : Fully modular construction (all circuit boards field-replaceable - no re-alignment necessary)

## DESIGN AND CONSTRUCTION

The FT-1 is a 'full chassis' design, built of 16 gauge steel in order to provide maximum rf shielding and to withstand the rigors of professional use. Yet its sleek, understated, front panel is elegant enough to compliment the component rack of the most appearance-conscious audiophile. The faceplate is available in two widths - 19 inch (483mm) with EIA rack mounting holes, and 17 inch (432mm) with no mounting holes. FANFARE is also studying the feasibility of manufacturing faceplates with special finishes and graphics to more closely co-ordinate with the more popular brands of high end components.

Components used in the manufacture of FANFARE products are the best quality and specially selected for use in radio frequency service. The microprocessor section is manufactured using computer grade parts and high reliability LSI devices. All push-button controls are reliability tested to rigorous standards.

# SETTING UP THE FT-1

Due to the proliferation of audio/video components now competing for space within many home entertainment systems, placement of the tuner has become no easy task. Therefore, if you have not already done so, take the time to plan the overall system in terms of component placement; cable lengths, identification, service access and your own personal safety. At the same time, take a moment to plan the integration of the FT-1 FM tuner into your system, taking into consideration its own special installation requirements.

**PLACEMENT OF THE FT-1** The allowable distance between the FM tuner and the line stage preamplifier depends on the method of transmission. Use of good quality, balanced interconnects will allow vast distances (100's of feet). However, if unbalanced interconnects are being used, the limits are more finite. If the line level (HI) outputs are being used, distances up to 25 feet may be possible but should be confirmed before making the installation permanent. Use of the LO level, unbalanced outputs may require a decidedly shorter run length of perhaps 36 inches or less.

Conversely, if the preamplifier is a microprocessor controlled (A/V) type, being too close may invite airborne rf noise to enter the tuner. It is always prudent to test-locate an FM tuner before confirming its location.

**CABLES AND CONNECTIONS** It is recommended that you place the tuner in a location convenient to being seen visually and by the remote controller if manual tuning is necessary. If visibility is not essential, placement should be within a reasonable distance of the preamplifier but well away from digital processing equipment, the power amplifier(s) and any other device that radiates electromagnetic waves.

The FT-1 requires 3 cable connections: (a) a stereo pair of line interconnects (b) a coaxial type antenna cable and (c) an ISE type power cord. Having determined what type of line interconnect will be used (balanced or unbalanced) and where the FT-1 will be located with relation to the preamplifier, all that is left to determine is the physical length of the interconnect pair.

One way to establish the ideal *interconnect cable* length is to simulate the run using a piece of zip wire (lamp cord) or light rope. Doing it this way will ensure that all the curves the cable is likely to make in its journey are taken into consideration. Run the wire or rope along the exact route you would like the interconnect to travel, dressing it neatly as you go along. Measure the wire or rope, then add 6 - 12 inches to provide some slack in the event you have to move the FT-1 or the preamplifier in and out.

*Remember, in situations where a number of cables are in use, as is usually the case with A/V preamplifiers, there must be sufficient give in the way the cables are connected. This is so they won't get pulled out by others running alongside them in the bundle, should the preamplifier be moved inadvertently.*

***IMPORTANT:** In order to protect sensitive components in your system (speakers etc.), always turn the amplifier and preamplifier OFF, before plugging in or unplugging interconnect cables.*

The *antenna cable* is one that should be run on its own, away from the rest of the cables, to lessen the possibility of induced noise.

The *power cord*, being detachable, allows you to substitute any good quality ISE type, molded cable assembly available, at whatever length is necessary. To minimize possible interference through the power lines,

DO NOT CONNECT THE FT-1'S POWER CABLE TO THE SAME OUTLET AS THE POWER AMPLIFIER.

## POWERING UP

When all cables have been properly connected and double-checked, turn on the amplifier(s), then the preamplifier, and finally, the FT-1. When power has been confirmed at each component, tune the FT-1 to a local station. You should now hear that station's programming.

AC POWER INLET  
120VAC - 50 WATTS MAX.  
0.5A Slo Blo FUSE

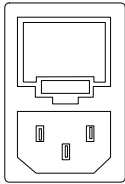

**CAUTION:**

RISK OF ELECTRIC SHOCK  
DO NOT OPEN

**WARNING:**  
TO PREVENT FIRE OR SHOCK HAZARD, DO NOT  
EXPOSE THIS UNIT TO RAIN OR MOISTURE. NO  
USER SERVICEABLE PARTS INSIDE. REFER  
SERVICING TO QUALIFIED SERVICE PERSONNEL.

ATTENTION:  
RISQUE DE CHOC. NE PAS ENLEVER.

*fanfare* Electronics, Ltd. Buffalo NY 14227

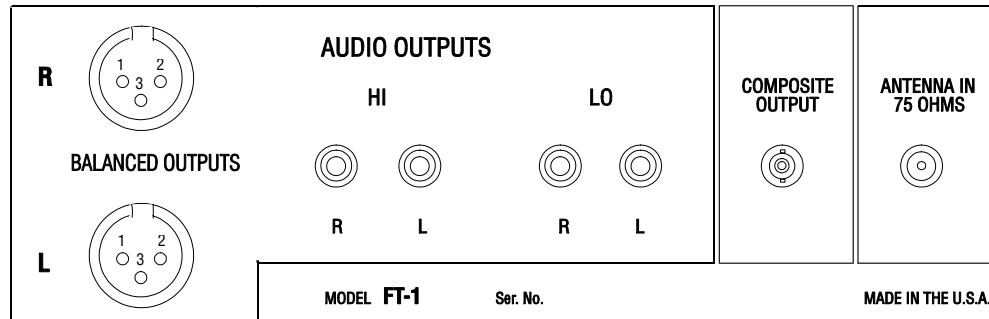

The FT-1 REAR PANEL

### THE REAR PANEL CONNECTIONS

CONNECTION	CABLE DETAIL*	DESCRIPTION
ANTENNA IN (75 ohm)		Accepts a standard F-type antenna coaxial cable connector.
COMPOSITE OUTPUT		Accepts a BNC-type connector. This output is primarily for use in an FM broadcast station. The Composite output from the FT-1 is adjustable from 2.5 - 4.5V(peak to peak) which is sufficient to drive most modulation monitors or FM exciters.
AUDIO OUTPUTS -LO		These are unbalanced (RCA-type) connections providing an unamplified, low impedance, audio signal direct from the tuner's multiplex filters.
" " - HI		These are unbalanced (RCA-type) connections providing line level audio output. Nominal output impedance is 47.5 ohms
BALANCED OUTPUTS		These are XLR-type connections providing balanced, line level, audio output. Nominal output impedance is 47.5 ohms. (0dB into 600 ohms). Connections: 1. GND; 2. (-); 3. (+)
AC POWER INLET		This is a fused, power receptacle allowing the user to disconnect the ISE type power cord as necessary. The removable fuse housing contains the 0.5A system fuse. There is also a compartment to hold a spare fuse.

\* Record the cable type and length in the event you have to replace it some time in the future.

# OPERATING THE FT-1

## APPLYING POWER

The FT-1 should be plugged into an AC power source that is not usually turned off. Once plugged in, the unit may be operated either from its front panel or from the remote controller.

## TUNE UP OR DOWN

For use if you wish to move quickly to a particular station frequency. (Scan MODE)  
Ensure that the tuner is in MONO mode ("STEREO" in display not illuminated). Pressing and holding down the UP button will cause the displayed frequency to increase. Similarly, holding the DOWN button down will cause the frequency to decrease.

When the top or bottom of the FM band is reached, the display will continue to tune up or down in the band from the top or bottom. For example, if you continue to press the DOWN button after the display reaches "87.50" it will begin again at "108.50". And, it will continue tuning in the downward direction until the DOWN button is released. A similar reaction in an upward direction will occur if the UP button is pressed continuously.

To return to stereo reception, press the STEREO button.

## TUNE - UP OR DOWN (SEEK MODE)

Ensure that the tuner is in STEREO mode and DX is 'on' ("DX" and "STEREO" showing in the display window). Press the UP or DOWN button and release. The display will begin ranging up or down in the direction selected. It will stop at the first station that is transmitting in stereo and is being received at a signal strength sufficient to provide at least 50dB of quieting. It will stay tuned to that frequency until the UP or DOWN button is pressed again. To stop the seek mode, press the STEREO button twice.

*Note: The seek speed will be noticeably slower than when it is scanning in mono mode. This is due to the fact that UNISET's digital circuitry is continuously sampling the output from the front end for (a) a station that is transmitting in stereo mode, and (b) at a signal strength that will provide full quieting (50dB or better). And it must do this in 50Khz steps.*

## THE DX FUNCTION

This function is useful in helping to control strong signals that abound in urban areas due to the large number of FM stations that are usually concentrated there. When the "DX" symbol is showing in the display window, the FT-1's front end is set for maximum sensitivity. When the DX button is pressed, the FT-1's sensitivity will be reduced by some 18dB. The lessened sensitivity will decrease the amount of incoming signal thereby reducing the possibility of interference and noise caused by strong, local signals.

Pressing the DX button switches the FT-1 alternately between DX and non-DX modes. The DX symbol illuminated in the display window indicates that DX has been invoked.

*Note: DX should be invoked at all times except when reception of a given station is actually improved by turning it off. It is also essential the DX mode be invoked whenever the 'Seek' method of tuning is being used.*

## STEREO/MONO

Pressing the STEREO button will alternately switch the FT-1 between 'stereo' and 'mono' reception mode. When the 'stereo' mode is invoked, the "STEREO" symbol will be illuminated in the display window.

*Note: When "STEREO" is displayed it is actually indicating the presence of the 19KHz stereo pilot signal being transmitted by the FM station. If the station is not transmitting in stereo, the STEREO indicator will not be illuminated.*

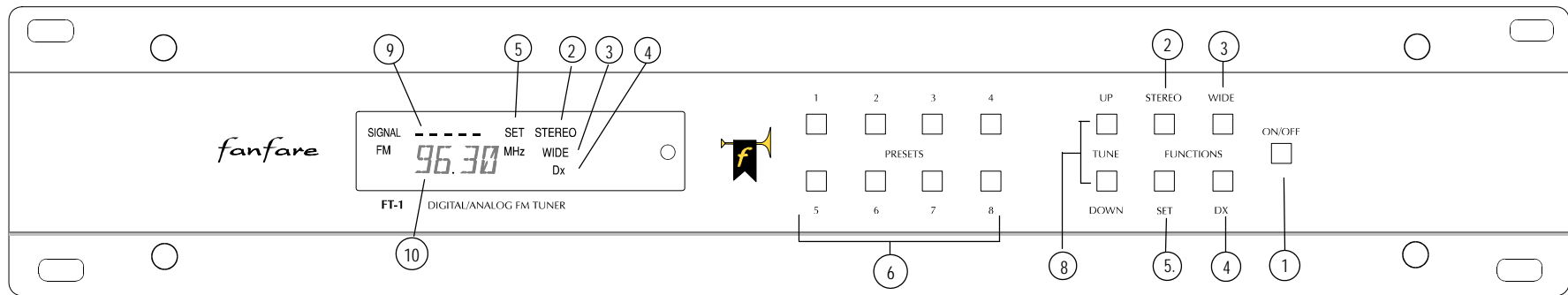

FT-1 Front Panel

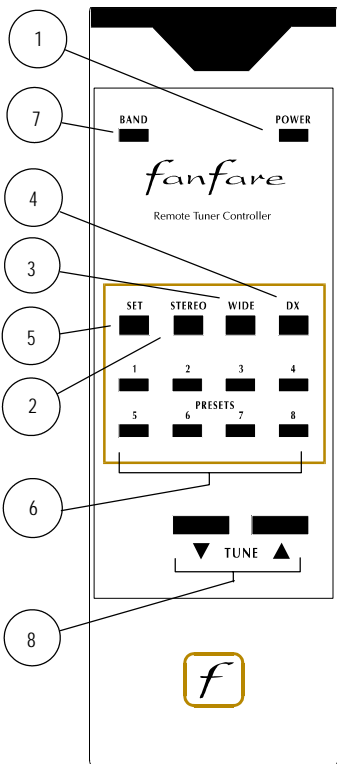

FT-1 Remote Controller

No.	FRONT PANEL	REMOTE CONTROLLER	DESCRIPTION
1	ON/OFF	POWER	Turns power on and off to the audio and display panel (6) circuitry. Note: The rf circuitry remains powered at all times when the unit is plugged in
2	STEREO	STEREO	Allows switching between stereo and mono modes. When in the stereo mode window will be illuminated any time a signal is being received from a station
3	WIDE	WIDE	Allows switching between 'wide' and 'narrow' bandwidth. When WIDE mode illuminated in the display window. When it is not illuminated, the tuner is in tl
4	DX	DX	Switches the DX mode 'on' and 'off'. When DX is invoked, the "DX" symbol it is not illuminated, the tuner's sensitivity will be attenuated by about 18dB.
5	SET	SET	Used to initiate the memorization of a station, along with configuration of all preset. When the SET button is pressed, the "SET" symbol (5) illuminates in t remain flashing for 7 seconds. To program a preset, the preset button must b
6	PRESETS (1 - 8)	PRESETS (1 - 8)	Used to store or recall a station and the desired mode settings to accompany i station to a preset.
7		BAND	NOT USED - - There is no function attached to this button at this time. This fun the button is pressed, The "AM" display symbol will be illuminated and a rand BAND button again to return to the previous display.
8	'UP TUNE' DOWN	h TUNE 'g	Adjusts station frequency. Place in MONO mode and press up or down button reached. To automatically seek listenable stereo stations, place in STEREO mc hold the button down). The display will stop at the next station that is being r stronger. To continue the search, press the up or down button again. Repeat t
9	SIGNAL STRENGTH DISPLAY		Indicates relative incoming signal strength. [5 segments illuminated indicates
10	FREQUENCY DISPLAY		Indicates tuned frequency from 87.5 through 108.5MHz in 50KHZ (0.050M

## Operating the FT-1 (cont'd)

### WIDE/NARROW

Pressing the WIDE button switches the FT-1 alternately between 'wide' and 'narrow' band mode. In doing so it allows you to switch between two levels of selectivity (IF Bandwidth) in order to deal with differing reception conditions that might be occurring with each FM station. Under good signal conditions, with no apparent sideband interference, the preferred mode would be 'wide'. In 'wide' mode, the "WIDE" symbol is illuminated in the display window.

If interference from adjacent stations is creating a reception problem it is recommended that you switch to the 'narrow' mode. Because the FT-1 has such excellent audio response, switching to 'narrow' band is not likely to alter the fidelity response curve in a particularly noticeable manner.

Remember that you can set whatever mode you find useful for any station and save the entire configuration to a preset. That way the station frequency, along with all the programming you did to establish best reception, will be recalled along with it.

### PRESET PROGRAMMING

When programming a preset, the desired station is tuned first. Then each of the subsidiary functions (STEREO, WIDE or DX) is set. Once you have determined which preset number (1 thru 8) to which you wish to save the current settings, press the SET button. The word SET will begin to flash in the display. In order for the program to be saved, the desired preset button must be pressed before the SET symbol stops flashing (approximately 7 seconds). If you do not make it in time, repeat the above procedure. Your programming will remain intact as long as you do not change either the station or the mode settings.

## THE FT-1 - 'UNDER THE HOOD'

At the heart of the FANFARE FT-1 FM tuner the design is analog. Why analog? Primarily because analog has proven itself to be the 'musical' choice when compared with most frequency synthesis (FS) digital designs. How the two differ is in their way of interacting with the signal coming in from the antenna. In an FS design, a 'black box' produces the necessary frequencies in order to convert the antenna signals. While such a process is efficient and inexpensive, the resultant audio very often has an edge or 'brittleness' to it. With analog, tuning is accomplished in discreet circuitry using tuned coils and MOSFET solid state devices. As a result, more of the music, along with its intrinsic and ambient qualities is more likely to be distinguished.

However, this does not preclude the value of digital circuitry as a useful technology when used in conjunction with a well co-ordinated analog design. The FT-1's unique UNISSET™ digital microprocessor is an excellent example of such usefulness, and plays a very crucial role in the FT-1's control system. As a matter of fact, UNISSET™ acts like a very good program manager by maintaining tuning accuracy at all times, along with providing the necessary reliability for the control features the FT-1 offers. As a matter of fact, the ostensibly transparent existence of the UNISSET™ monitor within the FT-1 has proven that it can actually enhance the already established smoothness and inherently musical characteristic of the tuner's audio output.

A more in-depth look at the FT-1 will show that the rf stages are analog using high quality varactor tuning devices and extremely sensitive MOSFET rf amplifiers. Coupling is precise to maintain maximum sensitivity right through the IF stages. Both the first rf stages and the local oscillator circuit are continuously monitored by the UNISSET™ microprocessor for tuning accuracy. In doing so, the UNISSET™ microprocessor reacts by adjusting the tuning instantly to compensate for any drift in the tuned frequency.

## The FT-1 - 'Under the Hood'

The signal then travels into the IF (intermediate frequency) stages where it is converted to a 10.7MHz IF signal. From there it is passed through the IF filter stages which consists partly of hand selected ceramic filters in order to provide best group delay characteristic (all signals arriving at the decoder stage at the same time). The signals are then sent to the stereo decoder where the stereo signal begins to take shape. Following that the signal is passed through another set of filters which clean the signal of any extraneous audio product that might otherwise influence shape and separation.

The audio signal is then distributed with one set of output leads being capacitor-coupled to the LO level, unbalanced, RCA-type, audio output jacks. The other set of outputs from the multiplex filters is sent to a high quality, audio grade amplifier stage. The amplified L & R signals are then direct-coupled to the input of the balanced outputs PCB which provides balanced audio outputs through XLR-type connectors. A set of leads is then direct-coupled from the (+) output terminals on the balanced PCB to the HI(line level) RCA-type, audio output jacks.

Direct coupling is preferred over the more traditional capacitor coupling. This is, in part, due to a more accurate, less colored rendering of bass and midrange. It also offers more consistency in manufacture from one unit to the next because there is no capacitor to capacitor variance to contend with. Finally, DC offset which is a great concern to most audiophiles is at absolute minimum, if present at all, as a result of in-line servo circuitry.

## What is UNISSET™

The term refers to a proprietary process within the tuner's microprocessor that:

- (a) constantly samples the frequency tuned for accuracy. Should a drift of any magnitude be detected, the UNISSET monitor instantly sends the necessary signal to the tuning stages to bring the tuner back to its correct setting.
- (b) stores the individual settings for each of the 8 presets for recall at any time.
- (c) carries out a search function when the UP(g) or DOWN(h) TUNE button is pressed (in STEREO mode only) by sampling each frequency in succession for a station transmitting in stereo at a signal strength of 55dB. Once a station meeting the search criteria is found, the search is suspended, the front end circuit is fine tuned, and the station is held. At that point, the station may be saved to a PRESET. The search may be resumed by pressing the UP(g) or DOWN(h) TUNE button again.

## IMPROVING YOUR FM RECEPTION

Perhaps the most important component in any radio reception system, aside from a well-designed FM tuner to translate the signal, is the antenna. As a matter of fact, when radio was first introduced, it was the efficiency of the antenna alone that determined signal strength and reception distance. Now, modern receivers and tuners have such phenomenal sensitivity that relatively distant signals can be received clearly with only a small, indoor antenna.

However, such an advance in technology was not made without its own form of 'Catch 22'. To wit, as the sensitivity of the receiver was increasing, so was its susceptibility to noise and interference. Surprisingly, along with industrial development and the concomitant noise being radiated from its various electronic and mechanised processes came the proliferation of radio stations, thereby adding their own form of 'roux' to an already thickening stew. Inevitably, this brought about the need for shielding against said interference, the most efficient of which was full metal cabinetry. As a result, the increased shielding has now denied entry to all but the strongest of signals. Hence, the need for an antenna which, whose efficiency we are now dependent on to provide us with the best reception.

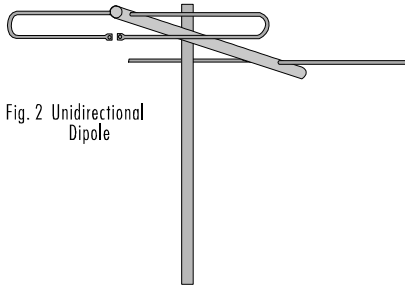

Fig. 2 Unidirectional Dipole



Fig. 1 Bidirectional Dipole

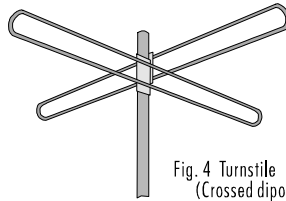

Fig. 4 Turnstile (Crossed dipoles)

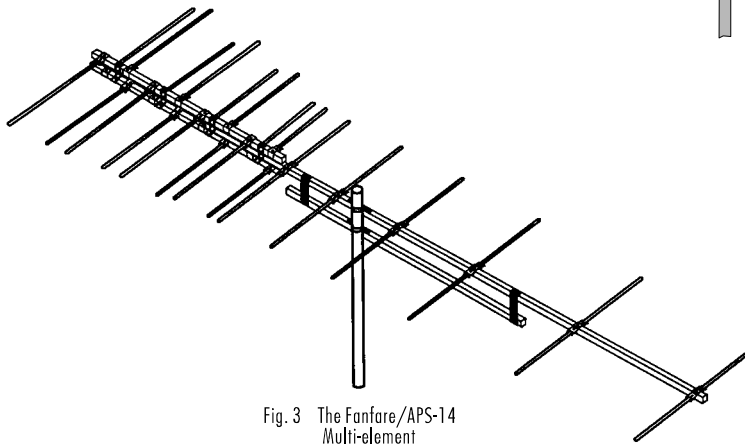

Fig. 3 The Fanfare/APS-14 Multi-element Array (yagi-type)

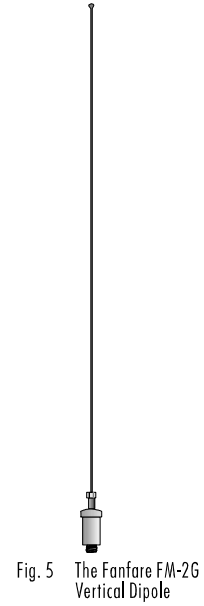

Fig. 5 The Fanfare FM-2G Vertical Dipole

### FM Antennas - Some common varieties

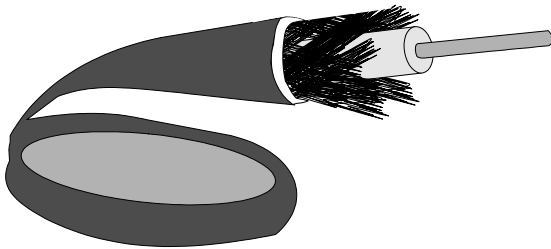
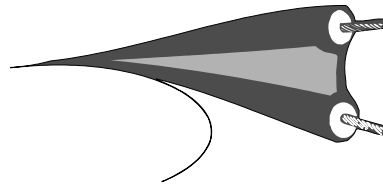

Fig. 6 75 ohm Coaxial Cable



Fg. 7 300 ohm Twin Lead

# CHOOSING AN FM ANTENNA

The most useful and appropriate antenna is one that is tuned to receive the FM broadcast band of 88 through 108 MHz. And, the best placement for the antenna is the highest possible location. Care must be taken that it be kept away from obstructions such as walls, chimneys etc. Also, it should not be placed near metal of any type, including furniture, eavestrouthing, railings, beside TV masts or near their 'guy' wiring. Such influences can reflect signals and create multipath problems. Or, the antenna could become detuned, thereby sapping its efficiency. Of the FM broadcast band antennas available, those illustrated on page 10 are most common.

**BI-DIRECTIONAL DIPOLE** - (Fig.1) This is perhaps the most commonly used FM antenna and exists as an industry reference (0dB) for most TV and FM broadcast band antennas. You have seen this design in its crudest form as the ubiquitous, wire dipole' found packed with just about every FM tuner and receiver. The dipole is also the basic element in both the 'unidirectional dipole' and 'yagi' antenna designs.

The single dipole receives equally well from front and back (referring to its two flat sides). Its sensitivity to radio signals is said to be at maximum when the antenna is positioned so that the center of its front or back sides is perpendicular to the radio transmitting tower. It is at minimum when the ends are pointing towards the radio tower.

**THE UNIDIRECTIONAL DIPOLE** - (Fig.2) This is a modified version of the bi-directional type. It has two elements and more gain. Functionally, it is able to concentrate its signal pickup within a broad but well-defined angle in the forward (dipole side) direction. This type of antenna would be recommended where the stations desired are in one general direction and moderately distant.

**MULTI-ELEMENT ARRAY** (Fig.3) This is an unidirectional antenna capable of maximizing the signal from very distant stations due to its high gain. However, this gain is directional and requires that the antenna be rotated each time you tune to a station that is 'around the compass' from the one tuned previously. A good quality antenna of this type, mounted high on a mast, should provide you with the best, unaided, FM reception possible. 'Yagi', 'collinear' and 'log periodic' are the most common of these high efficiency, multi-element array types. **Fanfare's APS-7** and **APS-14** antennas a very good examples of the yagi variety.

**TURNSTILE (CROSSED DIPOLE)** (Fig.4) This antenna came to pass as an attempt to establish an omni-directional receive pattern, without the need for rotating the antenna. Unfortunately, tests on this design have shown a reduction in efficiency (-3dB) when compared with the results obtained with a single, bi-directional dipole.

**VERTICAL DIPOLE** (Fig. 5) This antenna is the newest and perhaps the most revolutionary design on the market today. There are a number of distinct advantages offered by this antenna over the horizontally-polarized dipole. First, it is fully omnidirectional in its receptive capability. Second, it is receptive only to the vertically-polarized portion of the radio signal and is therefore less sensitive to multipath interference. Another advantage is the gain provided, which is usually in the area of 2.5dB over the dipole. Finally, being a 1/2 wave design, no 'ground plane' is necessary for its function. It can be installed on a mast or on any surface (metal, wood, fibreglass etc.), including that of a car, truck RV or boat. An excellent example of this antenna type is the **Fanfare FM-2G**, FM antenna.

**INDOOR ANTENNAS** There are a number of different designs on the market, some of which are 'active' (powered), with others being 'passive' (non-powered). However, the key to any antenna's effectiveness, active or passive, is its tuning and relative length. In other words, the exposed elements must be of a specific (tuned) length for maximum reception at a given frequency, in this case the 88 - 108 MHz band.

The most common antenna used in an indoor environment is the folded dipole type. Its physical length would be 1/2 wavelength (60" at 100MHz) and looks somewhat like the Bi-directional Dipole (Fig.1), but is shaped like a wide 'V' and sits on a stand. Placement of this type of antenna is usually governed only by the length of coaxial cable required and how much inconvenience the run presents.

Unfortunately, indoor antennas, if they are in a location where they will be seen, must conform to both size and appearance restrictions. This has spawned a bevy of 'powered' varieties which may conform to the 'appearance' requirement, but must be assessed in each and every reception situation for their relative effectiveness. The caveat here is definitely 'Try before you buy'.

## GAIN AND THE FM ANTENNA

The perfect antenna receives equally well in every direction. However, because our main concentration is on the area above ground level, a number of different ways have been developed to improve the antenna's efficiency and directional response. One is by transferring the antenna's receptive capability from one direction and 'adding' it, electrically, to the antenna's receptive capability in another direction. The best example of this is the "multi-element" antenna referred to in Fig.3. As an example, in designing the 'yagi' type of multi-element antenna, the dipole has been employed as the basic element. To the dipole an element has been added on one side which is called a 'reflector'. The reflector element now becomes the 'back' of the antenna and, as its name implies, it reflects the signal arriving from the front back to the dipole. In doing so it is also desensitized to signals arriving from the back thereby establishing the newly formed antenna as 'unidirectional' thereby adding to its sensitivity (electrically) to signals arriving at its front side.

In addition, tuned 'director' elements are placed in front of the dipole which have (a) the effect of narrowing the antenna's frequency response by further defining its 'tuned' attitude. In this case it would be the 88-108MHz FM band, and (b) an antenna that has been 'desensitized' to signals arriving at it from the sides and back, but through the electrical adding technique mentioned previously has been made even more sensitive to signals arriving at it from the front. The total amount by which it has become more sensitive, in relation to that of a single dipole, is called 'gain'. In terms of signal voltage, each 6 dB of gain represents a doubling of the signal voltage over that received using the reference dipole. In this context, the dipole is referred to as having 0 dB gain)

## ANTENNA DOWNLEAD CABLING

There are two types of cable in general use for home-type, FM antennas. One is the flat, twin lead cable that was introduced when TV became a fixture in the late 1940's. The second type is the now widely-used, 75 ohm coaxial cable, also referred to as RG59/U.

Speaking generally, a common grade of 300<sup>1</sup> ohm twin lead (Fig.7, pg.10) has about one half the losses that usually occur in a coaxial cable like RG59/U (Fig.6, pg.10) whose typical line loss is about 3.3 dB per 100 ft. at 100 MHz. However, along with being less expensive and easier to install, coaxial cable provides much better protection against interference pickup. The trade-off of less signal for a quieter and less expensive installation is often well worth it. However, the rural listener who is not particularly bothered by local interference might want to take advantage of the higher signal yield offered by 300 ohm twin lead when a long run of lead-in cable is necessary.

Finally, would-be antenna installers should keep the following in mind as they plan their installation. The two major contributors to lasting installation efficiency are: (a) a neat, well-thought-out; well-fastened cable run and (b) clean tight connections that have been protected against the elements. For coaxial cable a little silicone grease on the connector shells will help avoid corrosive build-up. For 300 ohm twin lead, the avoidance of running the cable near metal is important. If it must go over eavestroughing, pipes etc. make sure it is stood-off a distance of at least 6 inches to avoid picking up stray interference from the metal. Twin lead must also be twisted through 360 degrees for each foot of cable run to avoid becoming a long wire antenna itself and detuning the system.

## NOISE AND INTERFERENCE

There are two types of noise associated with FM reception. These are 'natural' and 'man-made'. Amongst the natural variety is atmospheric noise (lightning etc.). Man-made covers everything from machinery (diathermy equipment, electric motors etc.), to business equipment (FAX machines, computers etc.).

While atmospheric noise, with the exclusion of weather-related causes, can sometimes be minimized through use of an ultra-efficient antenna and lead-in system, man-made is more difficult to deal with. Usually it requires that either the offending source be moved away from the tuner, or its the antenna and lead-in, or vice versa.

Interference, other than from noise, most often originates with other radio transmitters and the only effective tool is to (a) maximize the tuner's selectivity and (b) to maximize the antenna's concentration on the station of choice. The FANFARE FT-1, operating in the 'narrow' band mode, already offers excellent selectivity. Therefore, initially, a concentration on the antenna system and its placement may be offer the most immediate results in minimizing obtrusive interference.

For more information on this subject, call for a copy of our booklet "Discovering Stereo FM".

---

<sup>1</sup> N.B The reference to 300 ohm cable excludes the shielded variety. This type has about the same loss factor as coaxial lead-in.

## LIMITED WARRANTY

FANFARE Electronics, Ltd., herein referred to as "FANFARE", guarantees this product to be free of defect in both material and workmanship and agrees to remedy any such defect or to replace any defective component at no charge for a period of three years from date of sale to the first end user. Should such a defect be discovered and its remedy is deemed by FANFARE to be covered under the terms of this guarantee, FANFARE will correct the defect in workmanship and/or replace any defective component with a serviceable component of similar capability and value.

This warranty is void if the product has been found to be subjected to misuse, abusive treatment, lightning strike or unauthorized service. This warranty is also void if the unit has been damaged in transit or has been altered or repaired in such a way so as to detract from its performance, its reliability or its safe operation. This warranty does not apply to the cabinet, the remote controller or appearance items such as the faceplate, control buttons or display lenses; nor does it cover any expenses incurred in shipping the unit to and from the FANFARE service depot.

The foregoing is in lieu of any other warranties expressed, implied or statutory and FANFARE neither assumes nor authorizes any person to assume for it any other obligation or liability in connection with the sale of this product. This warranty is not transferable or extendible except by written authorization from FANFARE. In order to qualify for transferability, the product must be registered with FANFARE within 30 days of the selling date by returning the enclosed Warranty Registration Card.

Defective units must be returned to the selling dealer. In the event the selling dealer is not readily available, the unit may be returned to FANFARE at the address below. In order to qualify under the terms of the above warranty, all items must be returned, adequately insured and with all shipping charges pre paid. FANFARE reserves the right to charge the return shipping costs to the sender if no defect is found in the alleged defective unit. In lieu of having previously registered the purchase of the unit by completing and returning the attached Warranty Registration Card, the unit must be accompanied by proof of purchase (bill of sale) from an authorized FANFARE dealer.

Before returning the product, a Return Authorization number must first be obtained from FANFARE. However, FANFARE does not assume nor does it accept any liability whatsoever in respect of any product, FANFARE or otherwise, being returned to FANFARE for any reason. Product arriving at FANFARE's service depot without a valid Return Authorization number showing prominently on the shipping container will be refused.

This warranty provides you with specific legal rights. You may also have other rights which vary from State to State. However, no warranty, implied or otherwise created by State law, shall extend beyond the term of this warranty and FANFARE FM shall not be liable for any incidental or consequential damage arising out of a defect in material or workmanship of the unit during the term of this warranty or thereafter. Some States do not allow the exclusion or limitation of incidental or consequential damages and the foregoing exclusions may not apply to you.

*fanfare*

Electronics, Ltd. 2100 Old Union Road, Buffalo NY 14227 (905)793-7953 FAX (905)793-5984

NOTE: IN ALL COUNTRIES, OTHER THAN THE U.S.A., DEFECTIVE UNITS MUST BE RETURNED TO THE SELLING DEALER.

My FT-1 serial number is \_\_\_\_\_ The selling Dealer is \_\_\_\_\_ Date of Purchase \_\_\_\_\_

Sold to \_\_\_\_\_ Address \_\_\_\_\_ Date \_\_\_\_\_

### SPECIFICATIONS

Usable sensitivity - mono	< 10.5dBf	Tuning range (50KHz steps)	87.5 - 108.5MHz
Usable sensitivity - stereo	< 11.5dBf	Signal-to-Noise Ratio(SNR) (A-weighted)	75dB
Sensitivity for 50dB quieting - mono	< 15.0dBf	Total Harmonic Distortion - mono	0.15%
Sensitivity for 50dB quieting - stereo	< 32.0dBf	Total Harmonic Distortion - stereo	0.30%
Audio frequency response (±1.5dB)	30Hz - 15KHz	Stereo Separation (1KHz)	40dB
Capture ratio	1.5dB	AM suppression	-70dB
Alternate Channel Selectivity - wide	55dB	SCA suppression	-70dB
Alternate Channel Selectivity - narrow	75dB	Power required	120/220/240 VAC* @ 50 watts
Adjacent Channel Selectivity - wide	10dB	Dimensions	19.0"(w) x 10.25"(d) x 3.5"(h)
Adjacent Channel Selectivity - narrow	25dB	Weight	16lb.(7.3 Kg)
			483mm(w) x 260mm(d) x 89mm(h)

## IN CASE OF DIFFICULTY

PROBLEM	POSSIBLE CAUSE	POSSIBLE SOLUTION
No display, no sound	<ul style="list-style-type: none"> <li>- Power cord not plugged in</li> <li>- Power off at AC source</li> <li>- Internal fuse blown or faulty</li> </ul>	<ul style="list-style-type: none"> <li>- Reconnect power cord</li> <li>- Check AC source (switch, fuse etc.)</li> <li>- Check for shorts or overloading*</li> </ul>
No sound. Display illuminated. All functions appear operational.	<ul style="list-style-type: none"> <li>- Tuner to line stage cables loose or faulty</li> <li>- Tuner not selected as source at Line stage .</li> <li>- MUTE invoked at Line stage.</li> <li>- Amplifier power turned 'off'.</li> </ul>	<ul style="list-style-type: none"> <li>- Tighten, repair or replace cable</li> <li>- Double-check source selection at Line stage.</li> <li>- Turn MUTE to 'off'.</li> <li>- Check amplifier for 'on' status.</li> </ul>
Unit will not respond to remote controller. Unit will not respond to front panel pushbuttons. (Display illuminated. Sound evident. )	<ul style="list-style-type: none"> <li>- Batteries dead or not installed correctly</li> <li>- Tuner's microprocessor 'locked up'.</li> <li>- Turning unit off does not solve problem.</li> </ul>	<ul style="list-style-type: none"> <li>- re-install or replace batteries</li> <li>- Turn unit 'off'. Wait 1 minute and turn on.</li> <li>- (Turn off preamp.) Disconnect power cord . Wait 30 seconds. Reconnect. (Turn on Preamp.)</li> </ul>
Loud hum or buzz on one or more channels	<ul style="list-style-type: none"> <li>- Poor ground connection in interconnect cabling</li> </ul>	<ul style="list-style-type: none"> <li>- Check all connectors and repair as necessary</li> </ul>
* If unit continues to blow fuses, have it serviced. - - - - <b>DO NOT USE A HEAVIER FUSE!</b>		

## SERVICING THE REMOTE CONTROLLER

Under normal circumstances, and if treated with reasonable care, the remote controller will offer no difficulty. It will, however, require a change of batteries every once in a while.

The frequency with which they need to be changed will depend on (a) the amount of usage and (b) the quality of the battery used. It is recommended that you use a good grade of alkaline battery to obtain longest life.

If the controller will be left unused for some time (more than two weeks), remove the batteries.

### INSTALLING NEW BATTERIES

To expose the battery compartment, locate the access panel on the rear of the controller. Use your thumb to slide the access panel downwards towards the bottom of the controller. If you are installing the batteries for the first time, remove any tape that might be binding the batteries together. Pay careful attention to the symbols shown inside the compartment. Orient each battery as shown and install.

To replace the access panel, slide it back on. **DO NOT ATTEMPT TO SNAP IT IN. YOU MAY BREAK THE PANEL'S LOCKING TABS.**

### CLEANING THE REMOTE CONTROLLER

Wipe with dry cloth. A dampened (not saturated) cloth may be used carefully to remove food stains etc. **DO NOT USE** DETERGENTS, DUSTING OR WAX COMPOUNDS. ESPECIALLY **DO NOT USE** CLEANERS WITH AN AMMONIA INGREDIENT (LIKE WINDOW CLEANER). IT WILL CAUSE THE FACEPLATE TO DISCOLOUR.

PLEASE NOTE THE COMMENTS IN THE WARRANTY STATEMENT ABOUT THE REMOTE CONTROLLER.



# APPENDIX 'A'

## 1. Removal and replacement of Faceplate - FT-1

## 2. Replacing display filter

### Preparing to Remove the faceplate - Precautions

While the most obvious way to mark a faceplate is to bang it against something, there is another that is less obvious. This occurs when you draw your finger across the faceplate against the texture grooves that were formed when the faceplate was 'brushed'. These grooves will act just like a very fine file and remove whatever is on your fingers. For example, in dry weather, you might leave a chalk-like mark which is composed of minute flakes of dead skin.

Any marks that appear on the faceplate may be cleaned using warm water and a mild detergent. DO NOT USE WINDEX, OR ANY CLEANING SUBSTANCE THAT CONTAINS AMMONIA, OR ANY OTHER CHEMICAL CLEANING COMPOUND. This will strip the anodize sealer from the surface of the plate. In time, this will cause a black faceplate to turn a multitude of colors ranging from purple to brown.

As the Limited Warranty packed with the Fanfare FT-1 states, all appearance items, including the faceplate are not covered.

### Removing the Faceplate

CAREFULLY, using a 5/32" allen hex wrench, remove each of the 4 screws that hold the front panel to the chassis.

To avoid the risk of damage of marking wear soft, clean gloves, or place a towel over the face and, grasping the faceplate through the towel, draw it forward from the chassis.

### Changing the Display Filter

While the FT-1 is shipped with green as the display color, the display material can be changed to any other color for which acetate or other clear, tinted material of a thickness not to exceed 3 thicknesses of the material already installed on the faceplate display window. The steps for replacement are;

1. Place the faceplate face down on something soft and non-abrasive. A clean towel will do nicely. If you wish to re-use the filter material being removed at some other time, use a glove or soft tissue to grasp the filter when following step 2.
2. At one end of the display material, carefully remove the tape. Use a utensil that can get under the tape so it will come off cleanly. Once the end is free from the faceplate, pull the material gently but firmly away from the taped end so that it 'peels' off the faceplate.
3. Clean the display window using a small amount of window cleaner on the end of a clean cloth. Remove the cleaner gently with a clean dry cloth. Apply only to the display window, on the back side of the faceplate. Do not rub hard or excessively. You are likely build up a static charge that will attract dust and lint particles.
3. Prepare the new display filter by applying a 1.5" piece of 1/2" tape across each end of the new material so that approximately 1/4" of tape overhangs the end and the sides. Blow off any lint or dust particles that might have landed on either the display material or the back side of the display window.
4. Holding the display filter by its edges, lay one end in such a way so the filter overlaps the display window's top, bottom and sides and that its edges lines up perfectly with the lines of the display window. Secure one end to the faceplate and then the other, keeping the filter material as flat to the display window as possible.

## APPENDIX 'A' (cont'd)

### Replacing the Faceplate

The tuner faceplate fits precisely on the chassis. The buttons will move freely in their respective cutouts when it is installed correctly. This can be done with a little care, patience and care. Just remember, the necessity to make very slight adjustments of the faceplate's position is important. If you move it too far in any one direction you will end up having to spend more time making the necessary adjustments so it will not bind on the pushbuttons.

1. Ideally, you will have the tuner in a position so that it can rest on its rear apron, with the front of the unit facing upwards.
2. Take precautions to avoid marking the faceplate. Placing a facial tissue over each end and grasping the faceplate through the tissue is often sufficient.
3. Place the faceplate on the front of the chassis in such a way so that you can see the ON/OFF button coming through its prescribed cutout hole at the right hand side of the group of control buttons. Then look downward into the rest of the holes and line up the faceplate so the buttons are directly under their respective cut-out hole.
4. Allowing the faceplate to rest on the buttons, move the faceplate gently from side to side. (about 1/8" is all the side travel usually necessary.) No further downward pressure should be applied. Do this until the faceplate drops down onto the buttons.
5. Reinstall the 4 Allen machine screws you unfastened when you removed the faceplate. Tighten only to the point where you feel the beginning of resistance. Do not tighten any further.
6. Set the tuner on its feet and press each button 3 or 4 times to ensure it is moving freely in its respective cut-out. If any button is not moving freely, determine on which side of the button the faceplate is binding and adjust the faceplate very slightly to relieve it. Once it is free, check the travel of each button again to ensure they are all moving freely.
7. Tighten the left upper screw and then the right lower screw in a similar fashion. Again check the buttons to see that they are not binding. Make adjustments as necessary to ensure they do not bind.
8. If no buttons are binding, tighten the screws hand tight starting again with the upper right, lower left, lower right and upper left.

Please note: If any button is not moving freely and sticks in the depressed position, it can possibly upset the operation of the tuner by causing the UNISSET™ microprocessor to lock up. Should that happen, unplug the tuner from AC power. Then adjust the buttons by first backing off the faceplate screws in the same order as explained in #8 above, and enough to allow movement of the faceplate. Again, follow the procedure as set out in 6, 7 and 8 above. Then, when you are certain all buttons are moving freely, plug the tuner back into AC power.

## APPENDIX 'B'

### Changing the AC input(mains) voltage

#### Preparation

1. Make sure the power cord is disconnected from the tuner's power inlet connector on the rear panel of the tuner.
2. Start with the tuner sitting on its feet with its faceplate facing you.
3. Remove the 4 screws from the tuner chassis top cover (2 screws each side).
4. Remove the top cover by lifting it straight up.
5. Place a hand towel or cloth over the faceplate to guard against accidental scratching.

#### Changing the input voltage

1. Looking towards the right rear of the chassis, you will see the power inlet receptacle where it is installed through the rear panel. On the front of the receptacle (the part that faces inside the chassis, near the top, you will see a wire plugged into a spade plug. Its color will be as follows;

#### **Primary Lead colors (from Power transformer)**

Yellow =- 120VAC    Orange = 220VAC    Red = 240VAC

Towards the lower portion of the receptacle there is a white wire attached. This is the neutral wire. DO NOT CHANGE ITS LOCATION.

Below that is a green wire which runs from a post on the floor of the chassis, near the barrier strip. This is the earth ground for the chassis and is not to be removed.

WITH THE GREEN WIRE ATTACHED, THE CHASSIS IS AT EARTH GROUND. HOWEVER, ALL AUDIO CONNECTIONS ON THE FT-1 ARE DESIGNED TO BE ISOLATED, OR TO 'FLOAT' ABOVE GROUND. DO NOT ATTEMPT TO CHANGE THIS BY GROUNDING THE AUDIO CONNECTIONS TO THE CHASSIS.

To the left of the receptacle there is a barrier strip. Two of the three above primary transformer leads will be attached to the barrier strip spade lugs. To change the input voltage;

- (a) Noting the color of the lead presently connected to the power inlet receptacle, remove that lead.
- (b) From the barrier strip. remove the lead of the color that represents the voltage you wish to change to and connect that to the recently vacated lug on the power receptacle.
- (c) Connect the colored lead removed from the power inlet connector to the recently vacated lug on the barrier strip. DO NOT CONNECT IT TO ANY OTHER LUG ON THE BARRIER STRIP. TO DO SO MAY DAMAGE THE TRANSFORMER BEYOND REPAIR.

# APPENDIX 'C'

## Changing FM De-emphasis

### Preparation

1. Make sure the power cord is disconnected from the tuner's power inlet connector on the rear panel of the tuner.
2. Start with the tuner sitting on its feet with its faceplate facing you.
3. Remove the 4 screws from the tuner chassis top cover (2 screws each side).
4. Remove the top cover by lifting it straight up.
5. Place a handtowel or cloth over the faceplate to guard against accidental scratching.

### Changing from 75 microseconds (North America) to 50 microseconds (Europe et al)

Looking towards the middle of the main circuit board locate the two, green, polypropylene capacitors marked "C16" and C18". They will be located right behind the blue trimpot labelled "Stereo Multiplex Adjust".

If your FT-1 is expected to remain in the country for which it s being, carry out the following procedure.

- With a small pair of electronics sidecutting pliers, snip the right and left leg of C16 at the circuit board and remove from the chassis. Do the same with C18.

If it is possible the FT-1 may be moved from the country in which this change is taking plae and will be brought back to North America, you have the option of making the procedure reversible by doing the following.

IF you are planning to return the FT-1 to the USA or Canada

- Instead of removing C16 and C18 from the circvuit, you may cut the inside legs halfway between the capacitor body and the circuit board (C16-right and C18-left) and fold each capacity over on its connected leg so that the side of the capacitor is parallel with the circuit board. Doing so does not in any way affect the rf circuit. When the action must be reversed simply bend the capacitor carefully back into place and solder-tack the legs that were cut back into their original position.

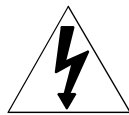

**CAUTION:**  
RISK OF ELECTRIC SHOCK  
DO NOT OPEN



**ATTENTION:** RISQUE DE CHOC ELECTRIQUE  
NE PAS OUVRIR

**WARNING:** TO PREVENT FIRE OR SHOCK HAZARD, DO NOT  
EXPOSE THIS UNIT TO RAIN OR MOISTURE.



**fanfare** electronics, ltd

P.O. Box 455, Buffalo NY 14225-0455 (716)683-5451 FAX (716)683-5421

On the internet "<http://www.fanfare.com>" via email "[info@fanfare.com](mailto:info@fanfare.com)"